

Festscheune

Party barn
Grange festive
Feestschuur

POLA G

Art. Nr. 331081

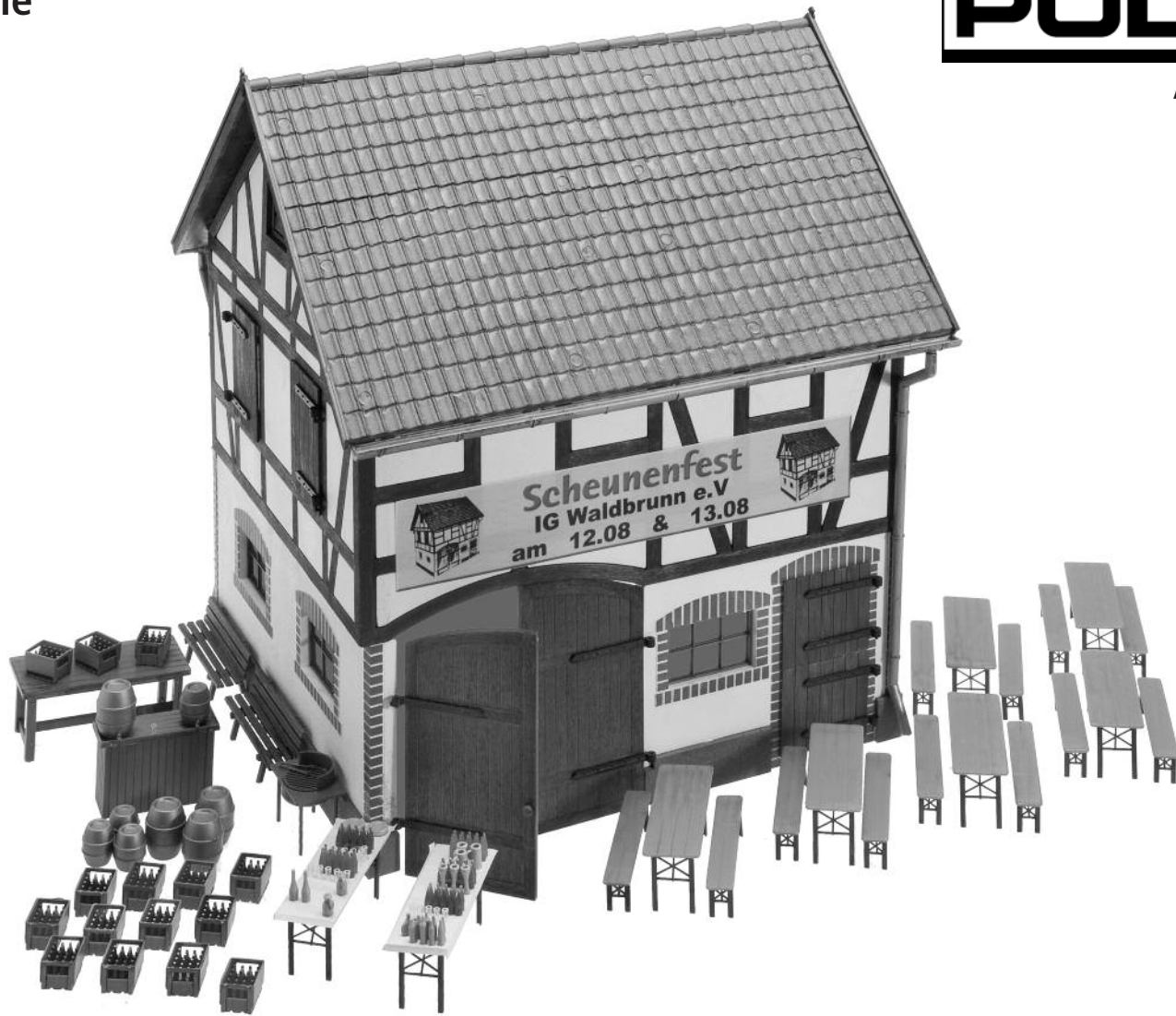

Sa. Nr. 331 081 1

- (D)**
- Verwenden Sie nur POLA G-Cement.
 - Machen Sie sich vor dem Zusammenbau gut mit den Einzelteilen des Bausatzes vertraut. Trennen Sie die Einzelteile erst dann ab, wenn sie gebraucht werden.
 - Verwenden Sie beim Zusammenbau wenig Klebstoff. Sie werden dann mehr Freude an einem sauberem Modell haben.
 - Sollte trotz werkseitiger sorgfältiger Prüfung ein Teil fehlen oder fehlerhaft sein, kreuzen Sie bitte das Teil in der Anleitung an und schicken Sie diese bitte an:
Gebr. FALLER GmbH, Abt. Kundendienst, kundendienst@faller.de, Kreuzstraße 9, D-78148 Gütenbach.
Sie erhalten dann umgehend Ersatz.

- (GB)**
- Use POLA G-Cement only.
- Familiarize yourself well with the components of the kit before assembly.
 - Do not break off the components until the moment you need them. Use glue sparingly on assembly, then you will enjoy your neat model even more.
 - If a part is missing or defective despite careful checking at the factory, please mark the part concerned in your instructions and send it to:
Gebr. FALLER GmbH, Abt. Kundendienst, kundendienst@faller.de, Kreuzstraße 9, D-78148 Gütenbach, Germany.
You will receive replacement promptly.

- (F)**
- N'utilisez que la colle POLA G -Cement.
- Avant l'assemblage, familiarisez vous avec les différentes pièces du jeu de construction.
 - Ne séparer les pièces particulières qu'au moment de les utiliser. Utiliser aussi peu de colle que possible pour l'assemblage, vous aurez d'autant plus de plaisir avec un modèle propre.
 - Si, malgré un contrôle soigneux à l'usine, une pièce devait manquer ou être défectueuse, marquer cette pièce d'une croix dans les instructions et envoyer ces dernières à:
Gebr. FALLER GmbH, Abt. Kundendienst, kundendienst@faller.de, Kreuzstraße 9, D-78148 Gütenbach (R.F.A.).
On vous la remplacera aussitôt.

- (NL)**
- Gebruik uitsluitend POLA G -cement.
- Zorg da u vóór de montage goed weet uit welke onderdelen het bouwpakket bestaat.
 - Maak de onderdelen pas los als u ze gaat gebruiken. Gebruik bij de montage slechts weinig lijm. U zult dan meer plezier beleven aan een schoon model.
 - Mist u ondanks zorgvuldige fabrikantencontrole toch een onderdeel of is een onderdeel beschadigd,
 - kruis dan het desbetreffende onderdeel aan in de handleiding en stuur dit s.v.p. aan:
Gebr. FALLER GmbH, Abt. Kundendienst, kundendienst@faller.de, Kreuzstraße 9, D-78148 Gütenbach, Duitsland.
Het wordt dan direct vervangen en naar u opgestuurd.



2

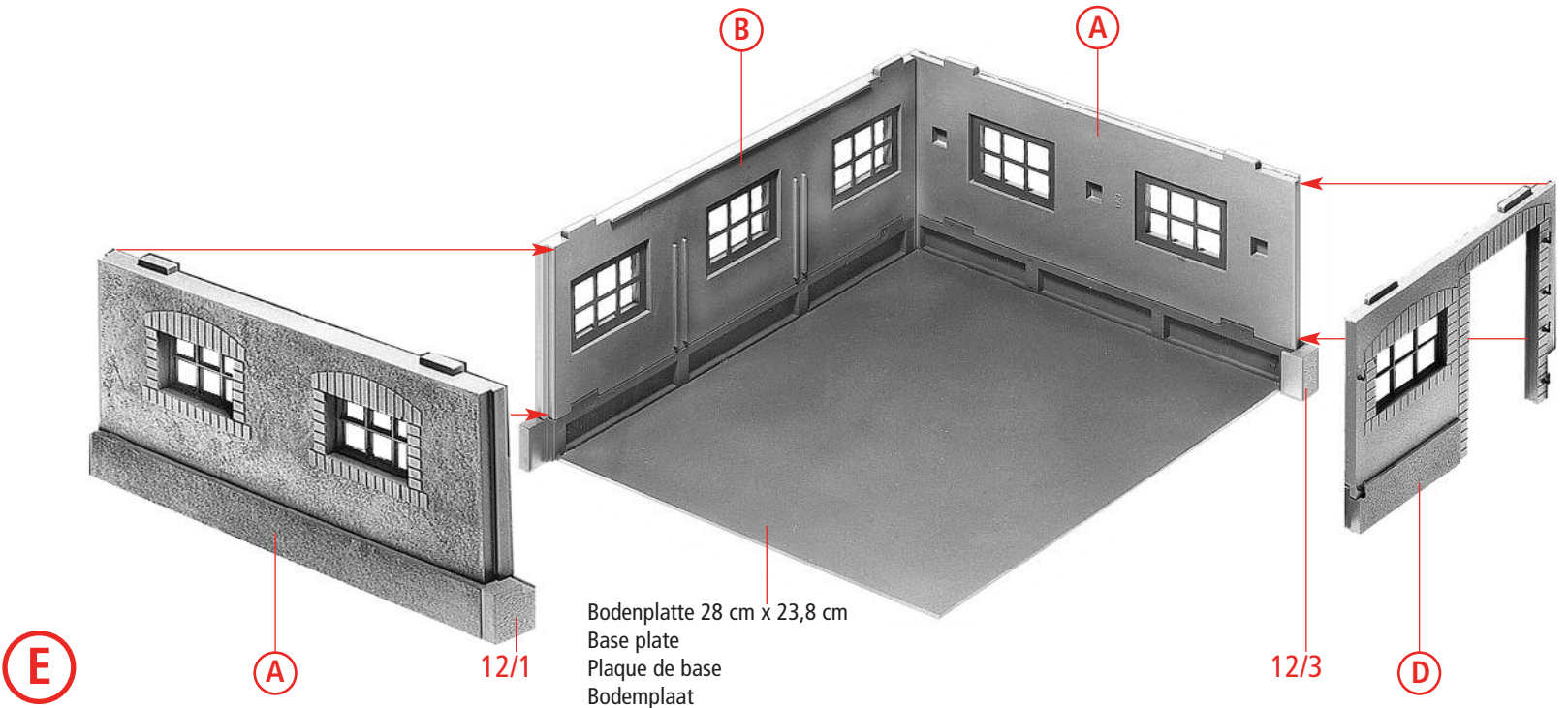
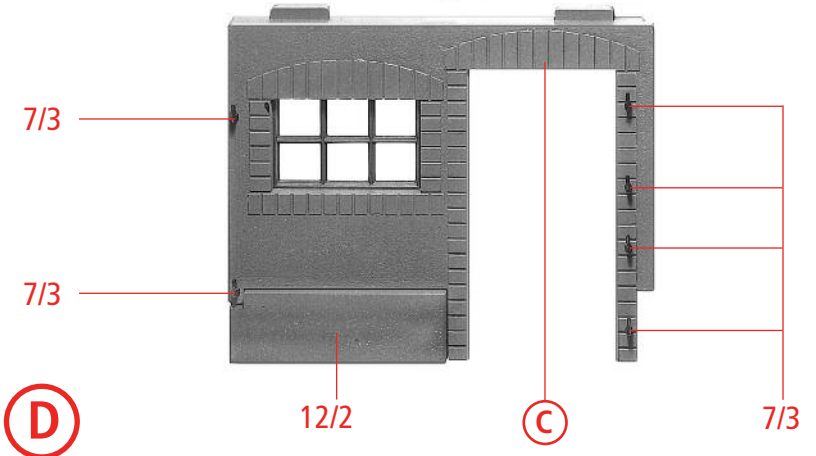
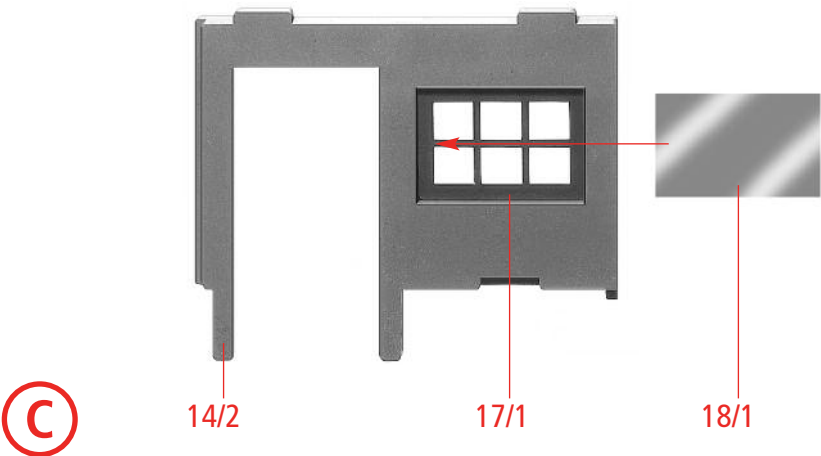
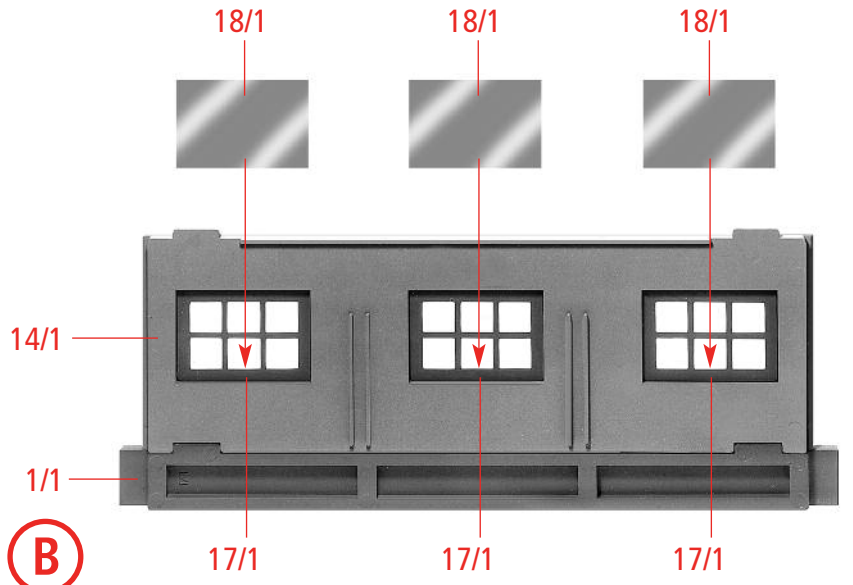
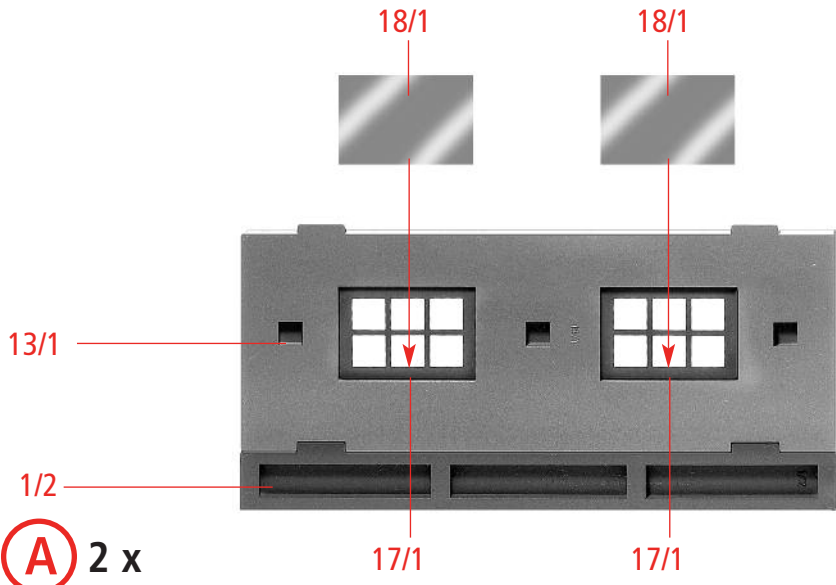
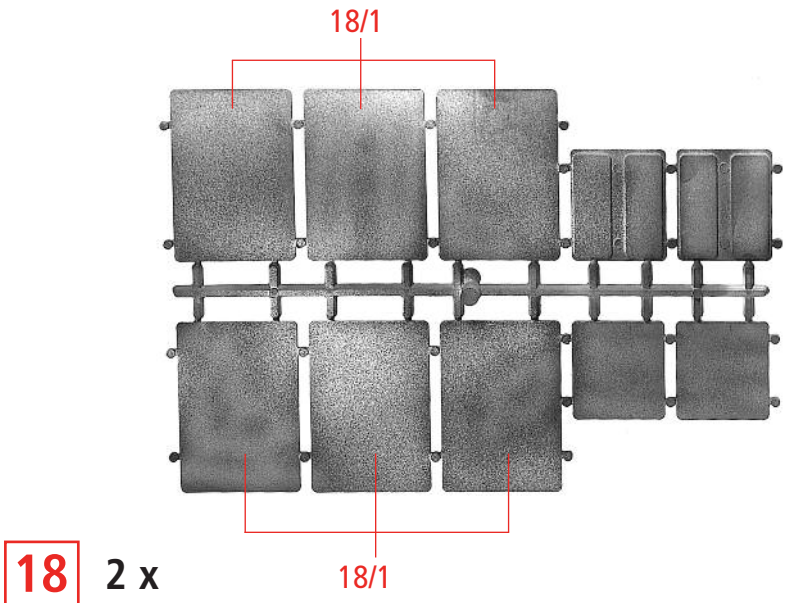
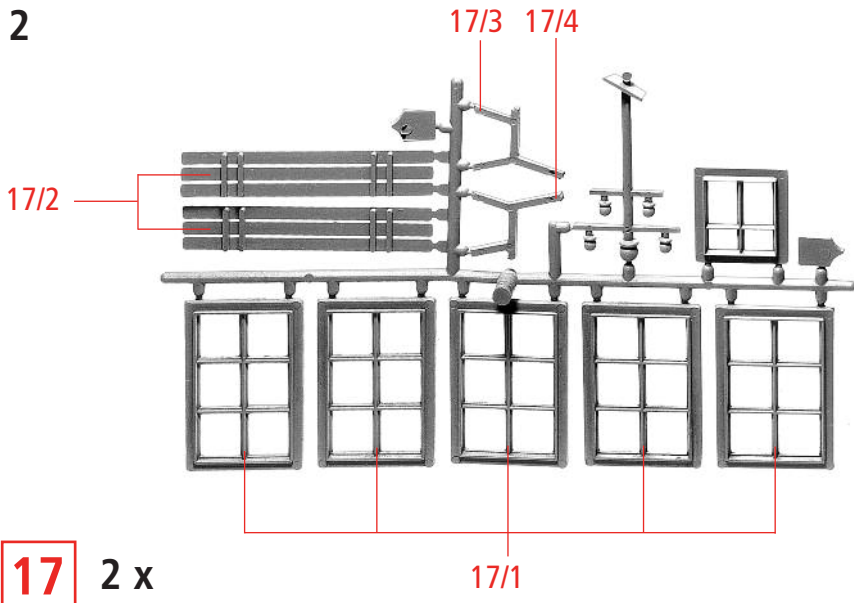

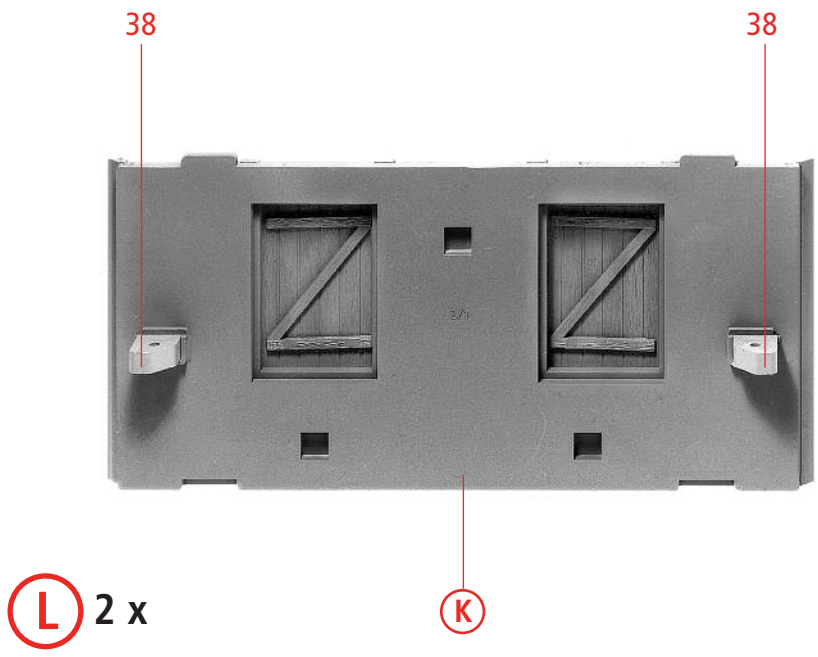
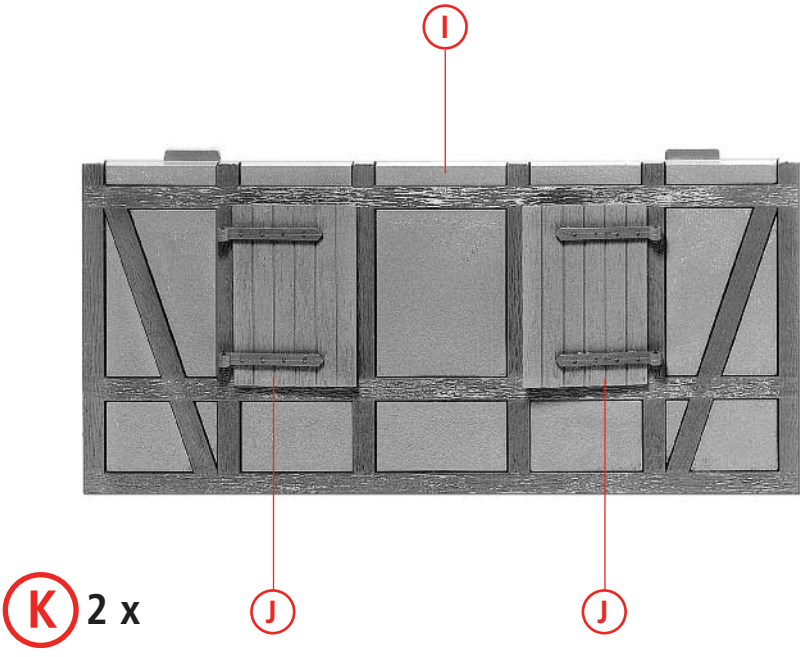
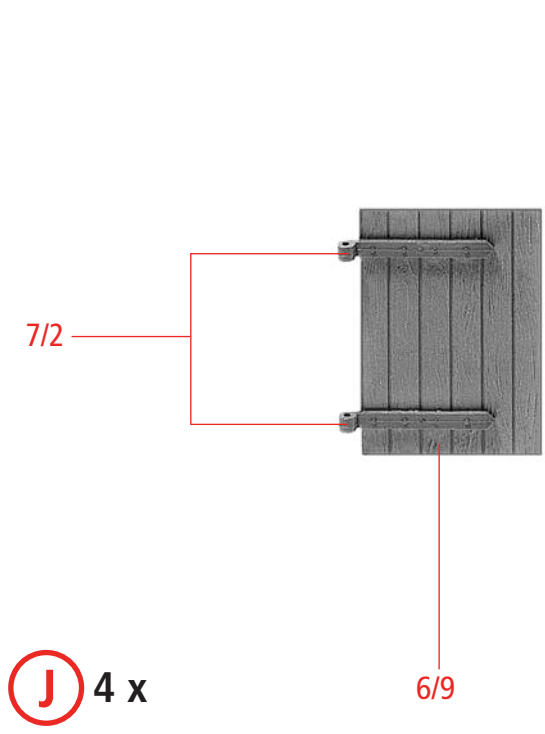
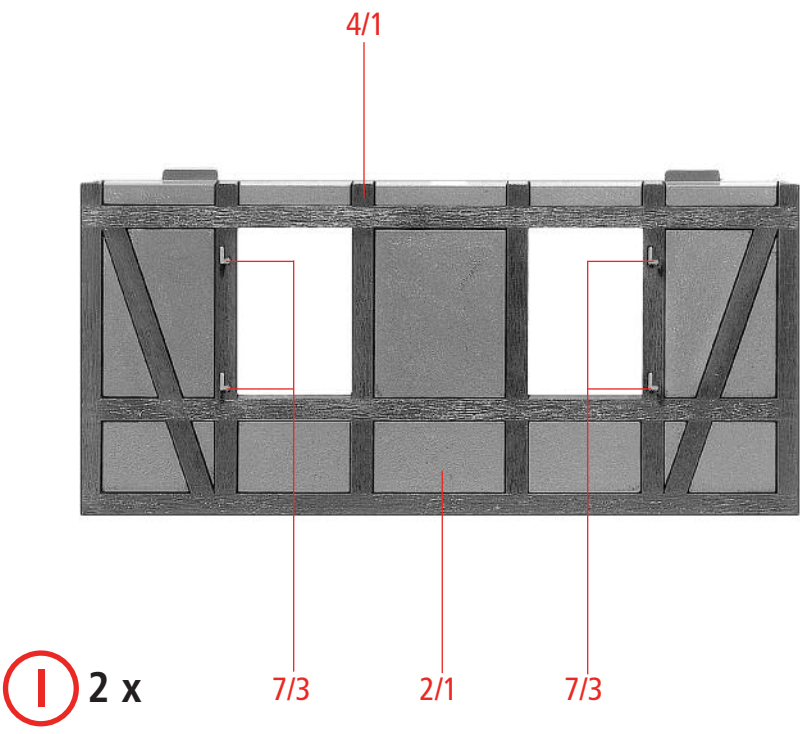
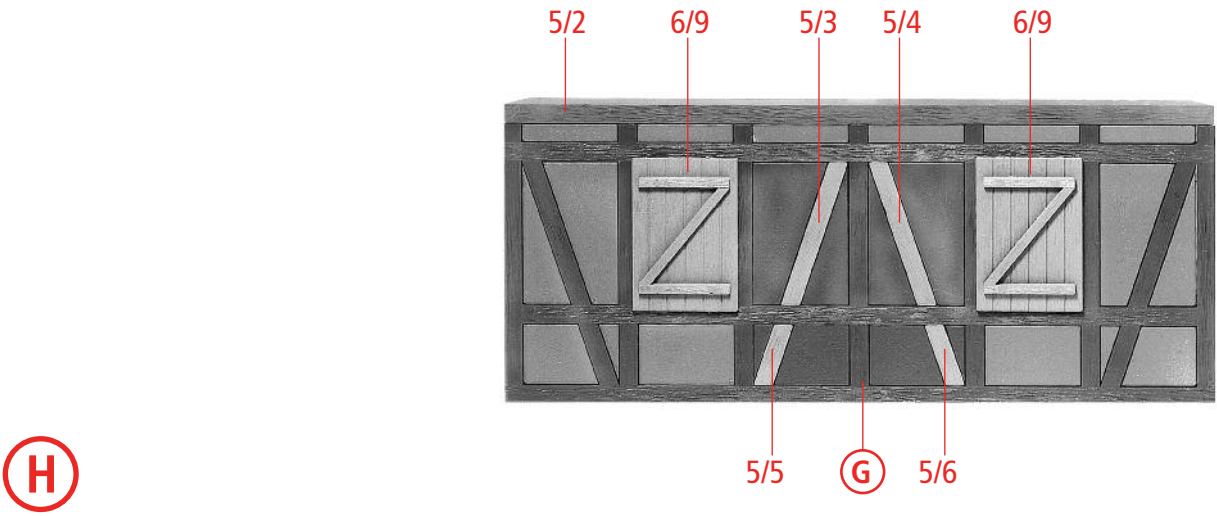
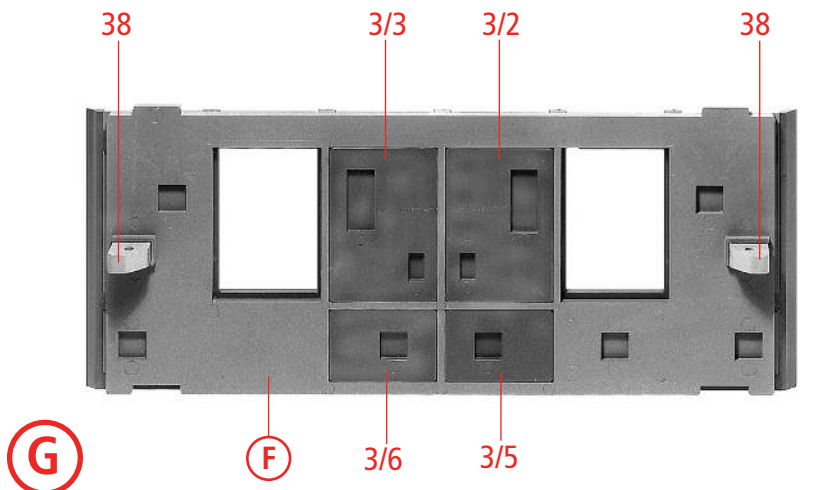
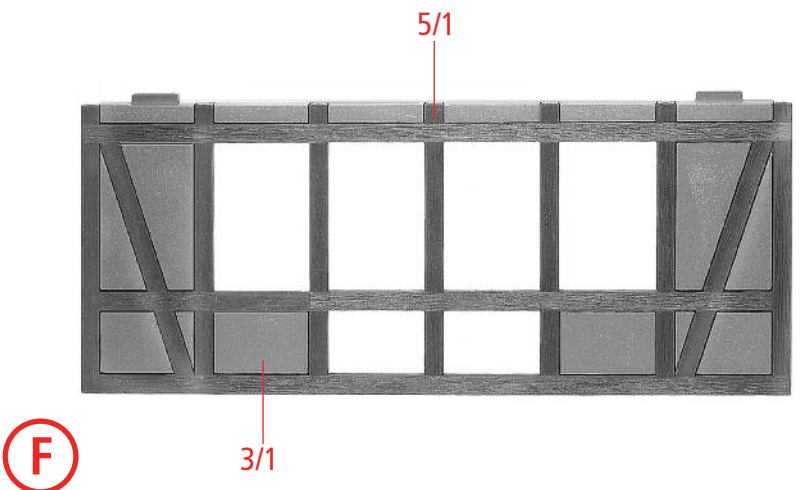

16/1

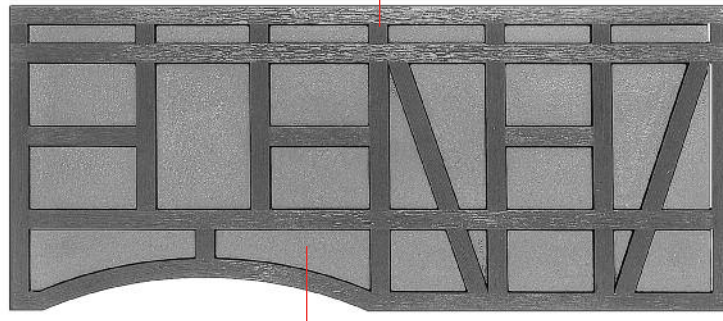

15/1

M

38



38

N

M

37 — nicht kleben
do not glue
ne pas coller
niet lijmen

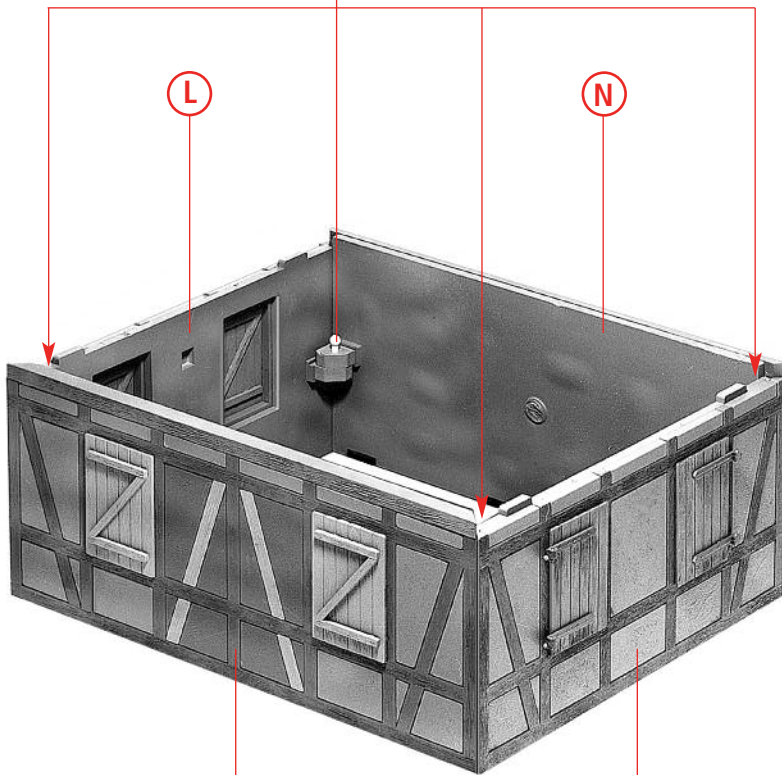

L

N

O

H

L

P

O



E

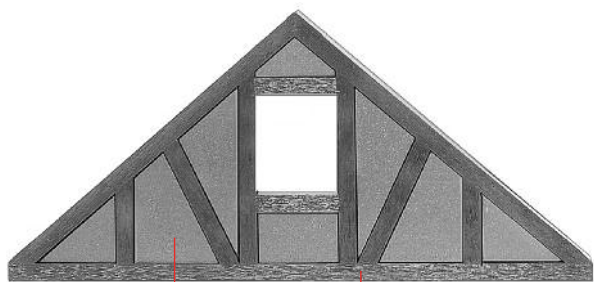

Q 2 x 2/2 4/2

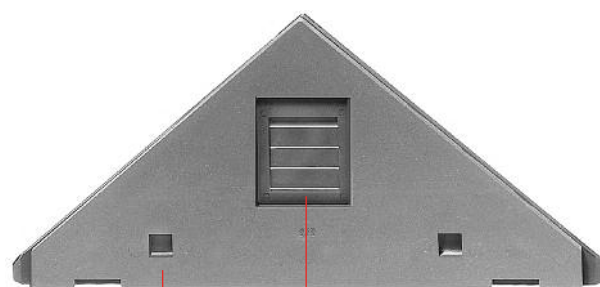

R 2 x Q 6/12

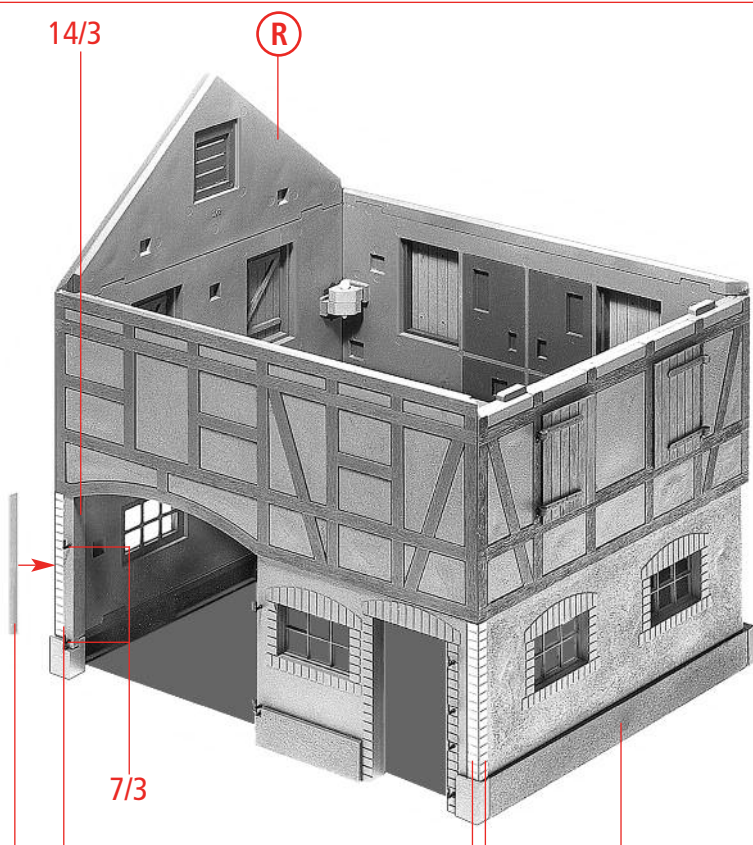

S 13/2 **P**

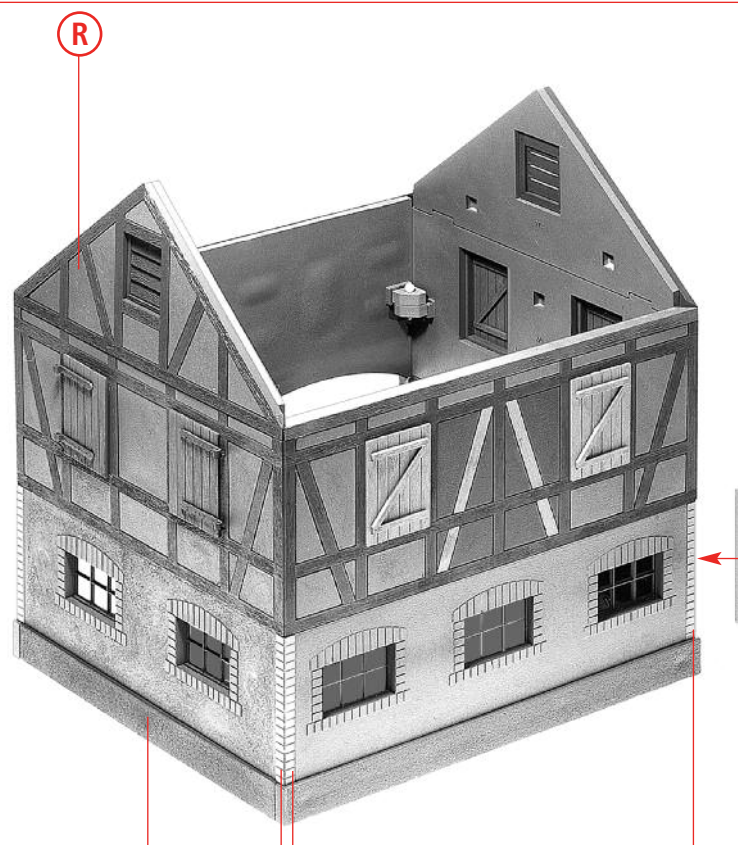

T 13/2 **S**

Vom Angußkanal zwei Stücke mit je 20 mm als seitliche Dacharretierung herausschneiden und ankleben.

Cut 2 pieces of 20 mm each from the feed channel and use them as a side roof lock mechanism.

Découper du canal de carotte deux pièces de resp. 20 mm comme arrêtage de toit et les coller.

Van de overgebleven gietdelen twee stukjes van elk 20 mm afsnijden en als dakversteving vastlijmen.

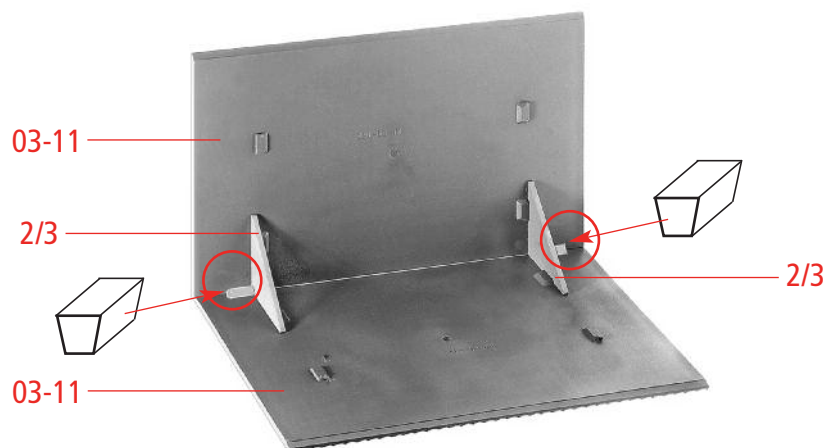

U Klebestellen gut abtrocknen lassen !
Allow glue joints to dry well !
Laisser bien sécher les points de collage !
Alle gelijmde punten goed laten drogen!

9/2 9/3 9/1 nicht kleben
do not glue
ne pas coller
niet lijmen **U** 9/5

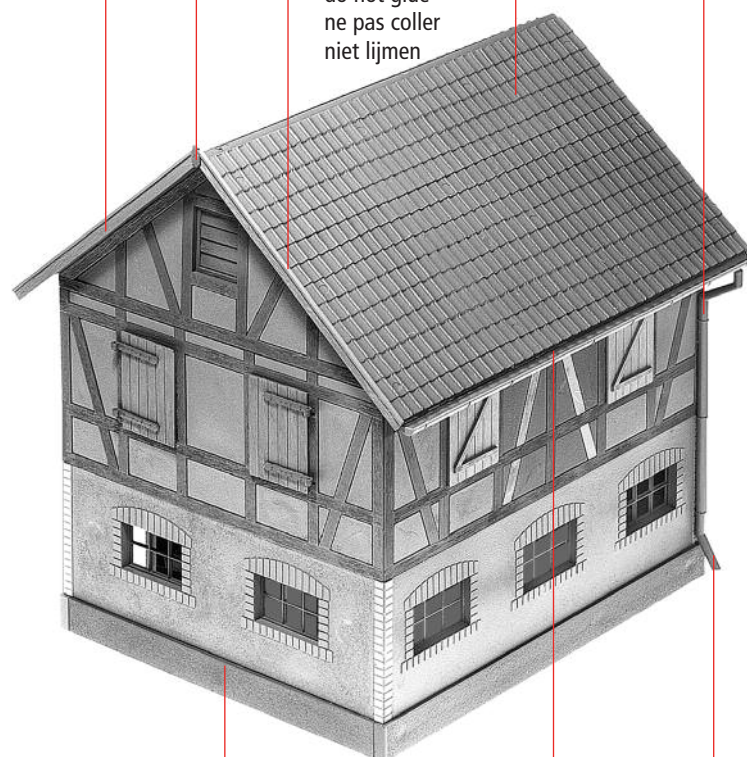

V 9/4 9/7 **T**

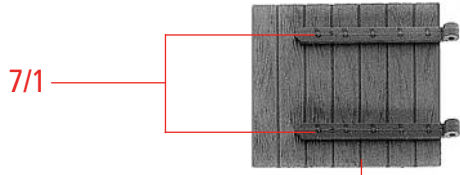

7/1

a 2 x

6/8

7/1

07-12

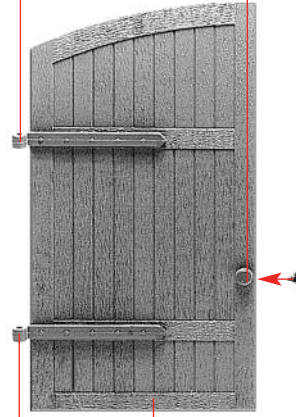

7/1

07-11

07-12

b

07-12

7/1

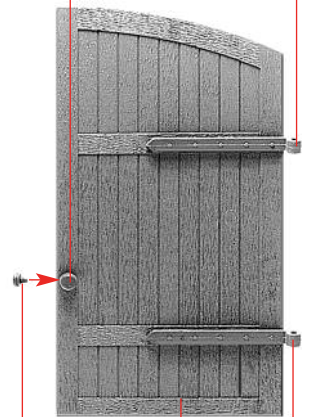

07-12

07-11

7/1

c

41



d

41



e

57 mm

9/2

9/3

9/1

68

68

d

e

9/5

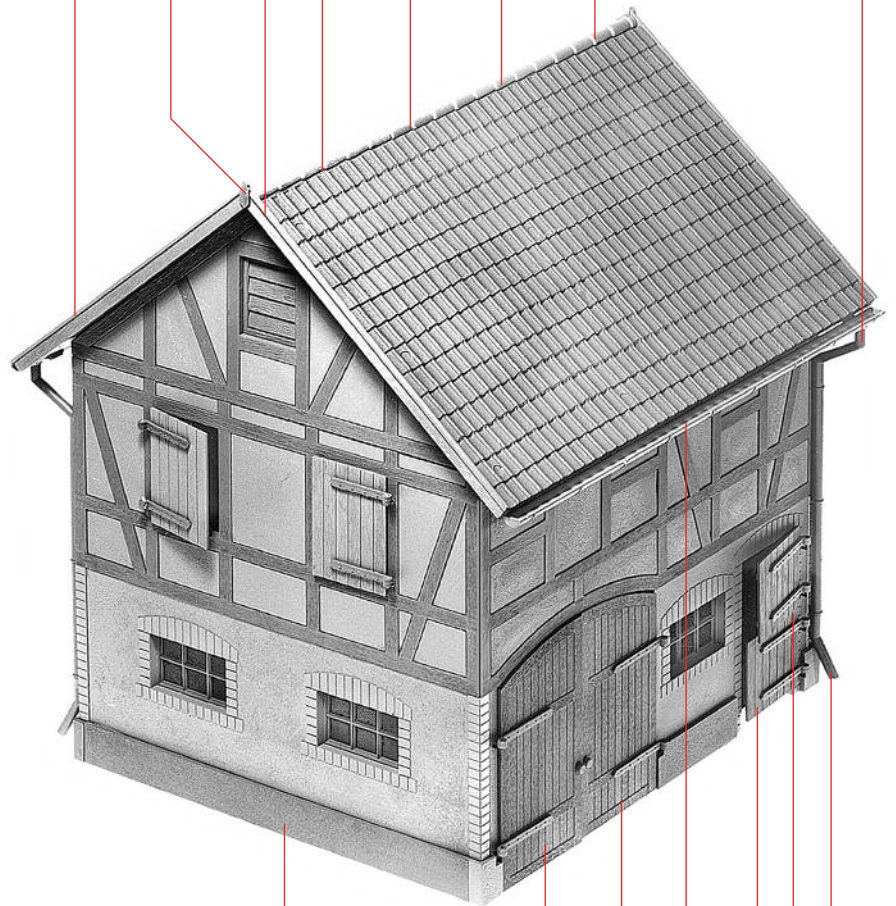

f

v

nicht kleben
do not glue
ne pas coller
niet lijmen

b

c

9/4

a

9/7

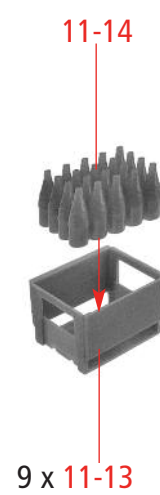
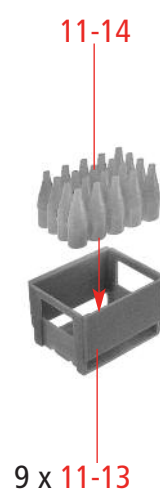
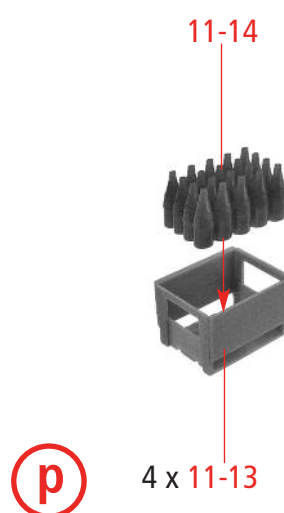
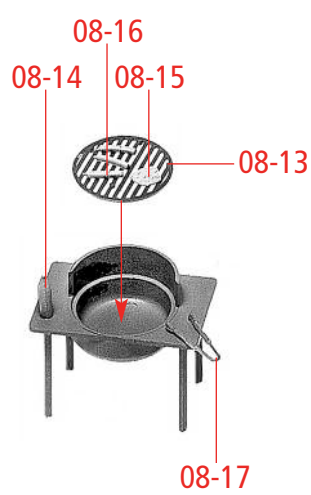
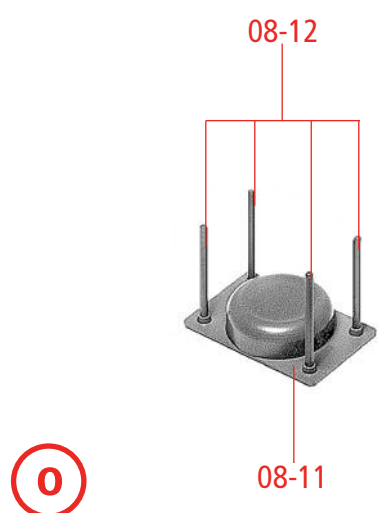
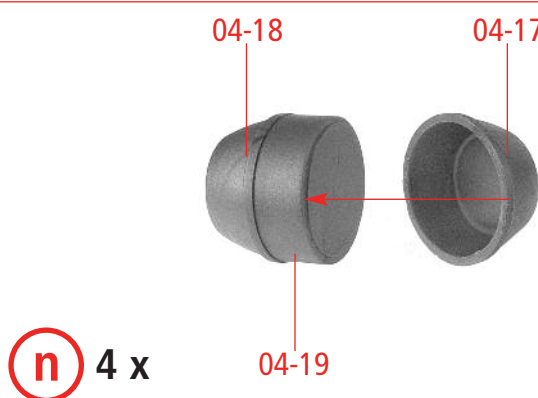
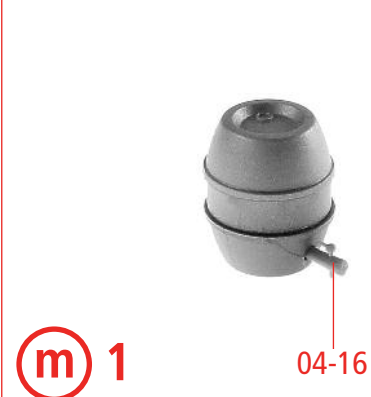
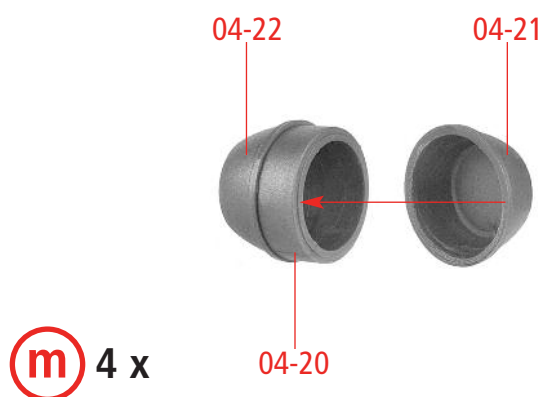
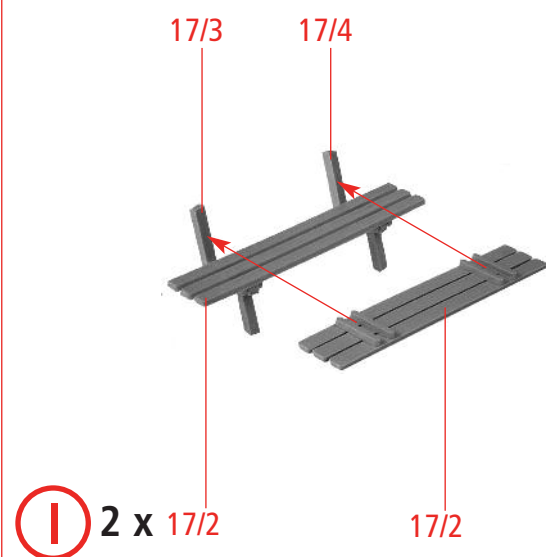
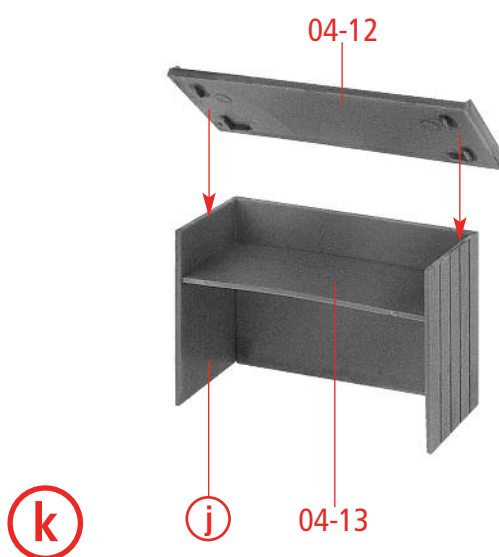
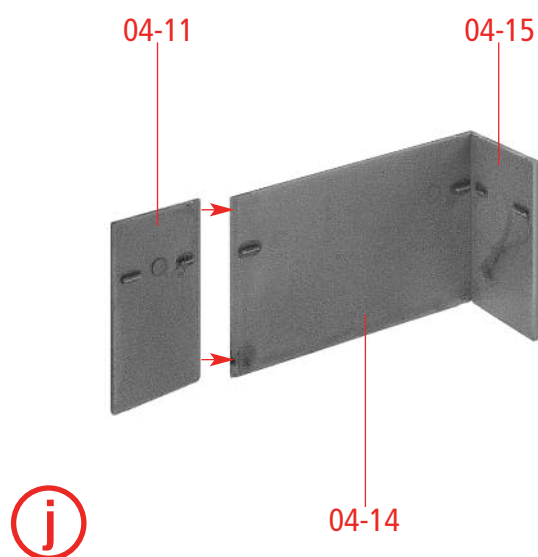
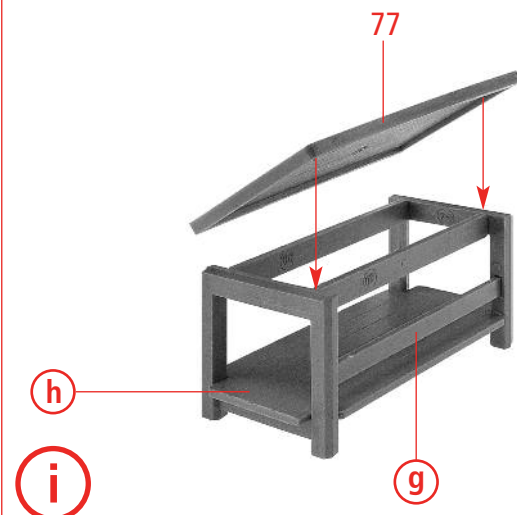
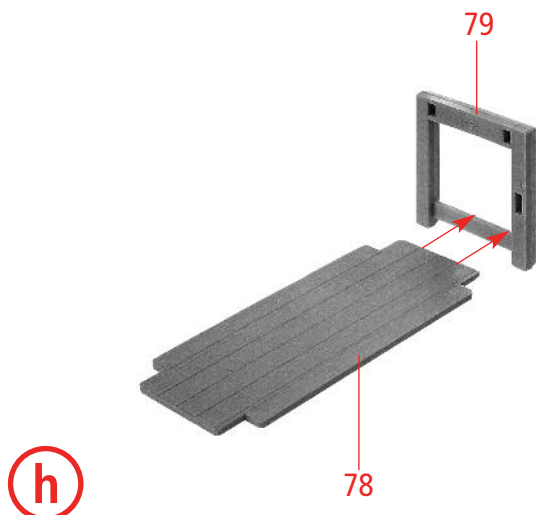
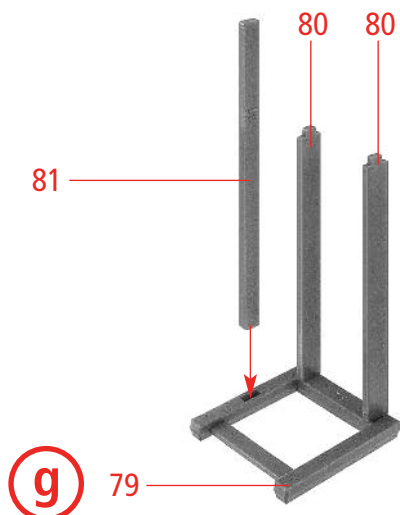

8

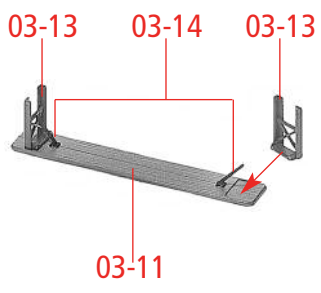

q 16 x

03-11

r

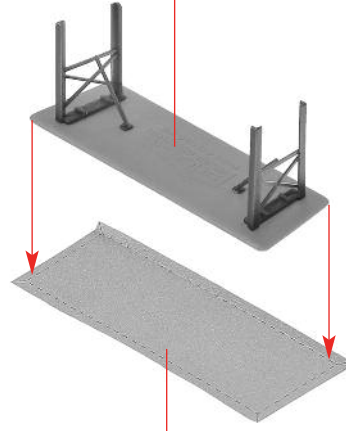

s 2 x

Deco 2

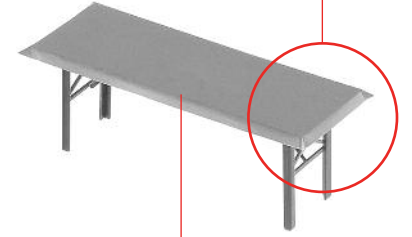

t 2 x

s

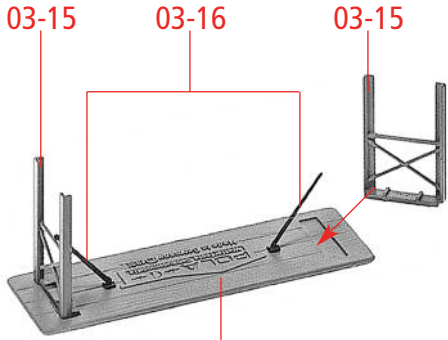

r 8 x

03-12

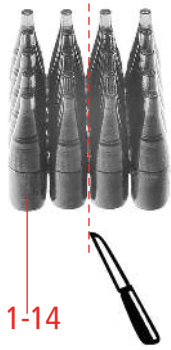

u

11-14

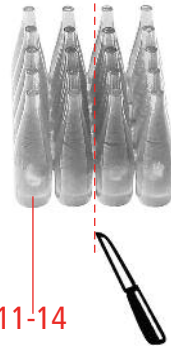

11-14

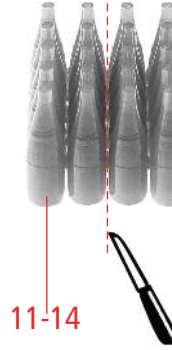

11-14

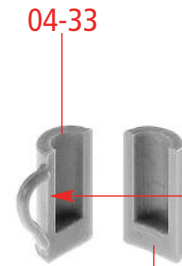

v 6 x

04-11

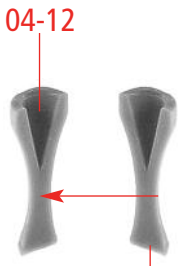

w 4 x

04-12

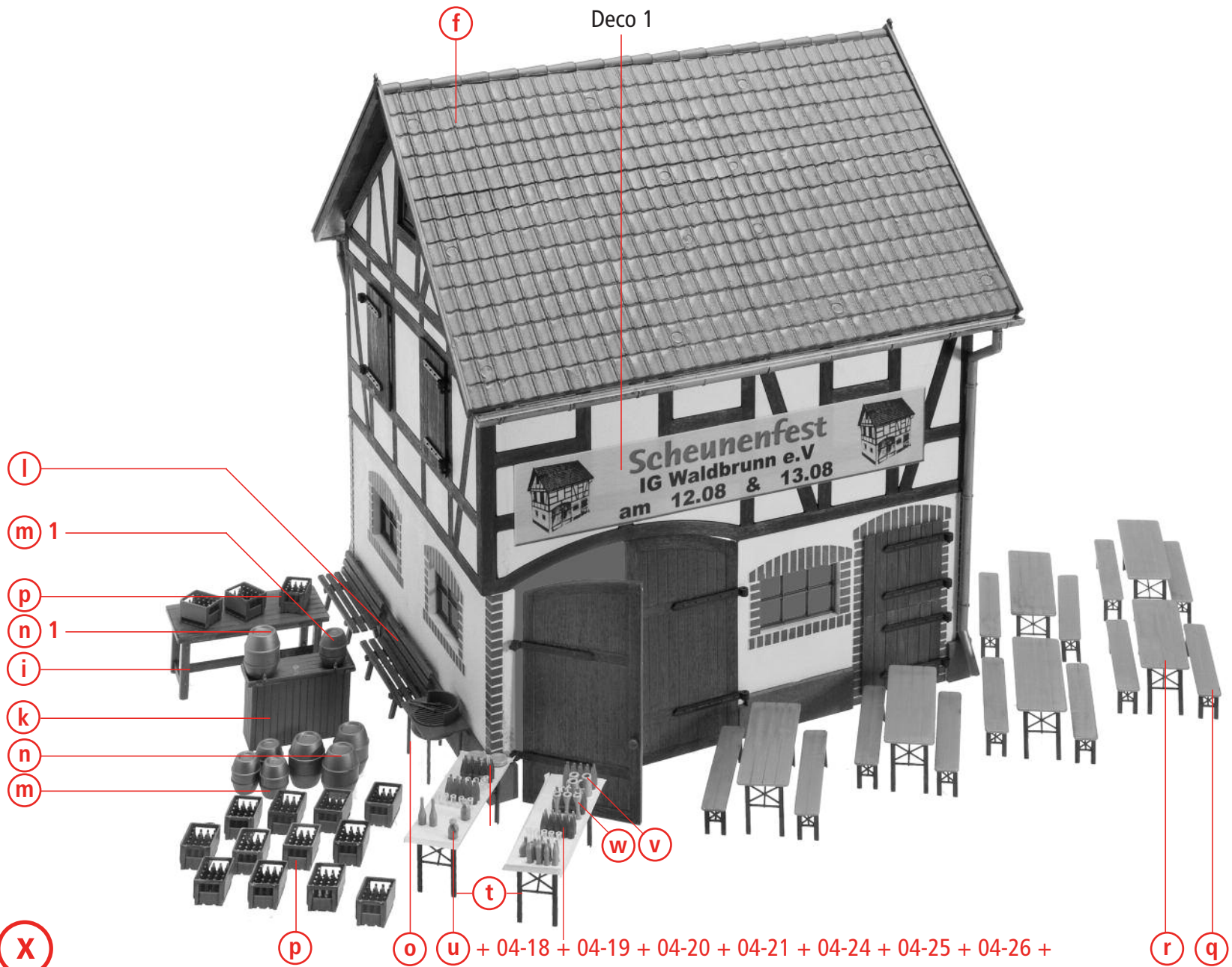

f

Deco 1

l

m 1

p

n 1

i

k

n

m

x

p

o

u

+ 04-18 + 04-19 + 04-20 + 04-21 + 04-24 + 04-25 + 04-26 +

w **v**

t

r

q